



# FUSION-PV™ HVLS FAN

## PHOTOVOLTAIC PRODUCT SPECIFICATIONS

HIGH VOLUME LOW SPEED FAN

### Design Highlights

- Large “Air Current Depth” - horizontal floor jet of 6-8 ft (1.8-2.4 m)
- Contributes to LEED® Certification credits and qualifies for most energy rebate programs
- Enclosed extruded aluminum frame
- Integral 1/3 HP motor and helical gearbox with onboard solar charge controller
- Includes three 185-watt mono-crystalline solar panels and mounting racks
- High performance blades optimize forward and reverse functionality
- Anodized protected blades are corrosion-resistant
- Load reducing Universal Mount System
- Patent pending Blade-Lock Safety System™ includes guy wires and safety cable
- Strong and durable Hybrid Hub
- Reversible Blade Struts for superior blade connection to hub
- Premium wiring package reduces installation costs (labor and material)
- Motor Control Panel includes serviceable On/Off Disconnect with lock-out/tag-out capability
- Remote Variable Speed Control

### Fan Diameter

- 16 FT (4.9 M)
- 18 FT (5.5 M)
- 20 FT (6.1 M)

### Available Options

- Powder Coated Blades \_\_\_\_\_
- Colored Anodized Blades \_\_\_\_\_
- Heresite Coating
- Hot Dip Galvanized
- Glulam Clamp (For Wood Structures)
- Extra Wide Beam Plate
- Super Short Mount
- Mounting Extension \_\_\_\_\_ FT / M

### Project Information

Job Name \_\_\_\_\_  
 Address \_\_\_\_\_  
 General Contractor \_\_\_\_\_  
 Distributor \_\_\_\_\_  
 Model \_\_\_\_\_ Quantity \_\_\_\_\_ Voltage/Phase \_\_\_\_\_

### Certified For Construction

By \_\_\_\_\_  
 Company \_\_\_\_\_  
 Address \_\_\_\_\_  
 Date \_\_\_\_\_

# KELLEY FUSION-PV™ HVLS FAN

## Construction

Hybrid Frame ..... 6061 Aluminum  
 Hybrid Hub ..... 356 T-6 Cast Aluminum  
 Solid Steel Blade Struts (Invertible) ..... Zinc Plated/1020 Cold Rolled Steel  
 Blades ..... Anodized / 6063-T6 Aluminum  
 Wiring Loom ..... PV Cable Assembly Solar Panels to Service Disconnect  
 Service Disconnect ..... NEMA 4X Enclosure with Load Protection

## Solar Panels (3)

Power ..... 3 x 185 Watts  
 Dimensions ..... 39" x 53" x 1.5" (991 x 1346 x 38 mm)

## Safety Components

Blade Retaining Links (6) ..... Zinc Plated / 10 GA A569 Steel  
 Safety Cable ..... Galvanized / 1/4" x 7 x 19 Steel Aircraft Grade Cable  
 Guy Wires ..... Galvanized / 1/8" x 7 x 19 Steel Aircraft Grade Cable  
 Safety Link Extenders (6) ..... Zinc Plated / 10 GA A569 Steel  
 Frame integration ..... Zinc Plated / 3/16 A569 Steel

## Mounting Hardware

Standard Mount ..... Universal I-Beam Clamp w/ Swivel Joint & 12" Drop  
 Glulam Mount (Optional) ..... Brackets w/ Swivel Joint & 12" Drop  
 Extra Wide / Thick I-Beam Mount (Optional) ..... Consult Factory  
 Additional Drop Extensions (Optional) ..... Up to 10 FT in 1 FT Increments

## Motor/Controller

Remote Control Wall Mounted Switch NEMA 4X ..... Fwd/Off/Rev w/Speed Control Knob  
 HP ..... 0.33 / 0.25 Kw  
 Volts ..... DC 15-30v  
 Insulation Class ..... F  
 Maximum Current ..... 25 Amps

## Gearbox

Type ..... 2-Stage Helical  
 Service Interval ..... Lubed For Life

## Options

Power Supply ..... Plug in Power Supply and Auxiliary Backup

## Warranty

Blades, Hub & Mounting System ..... Limited Lifetime  
 Drive System ..... 12 Year Limited  
 Solar Panels and Mounting Racks ..... 10 Year Limited

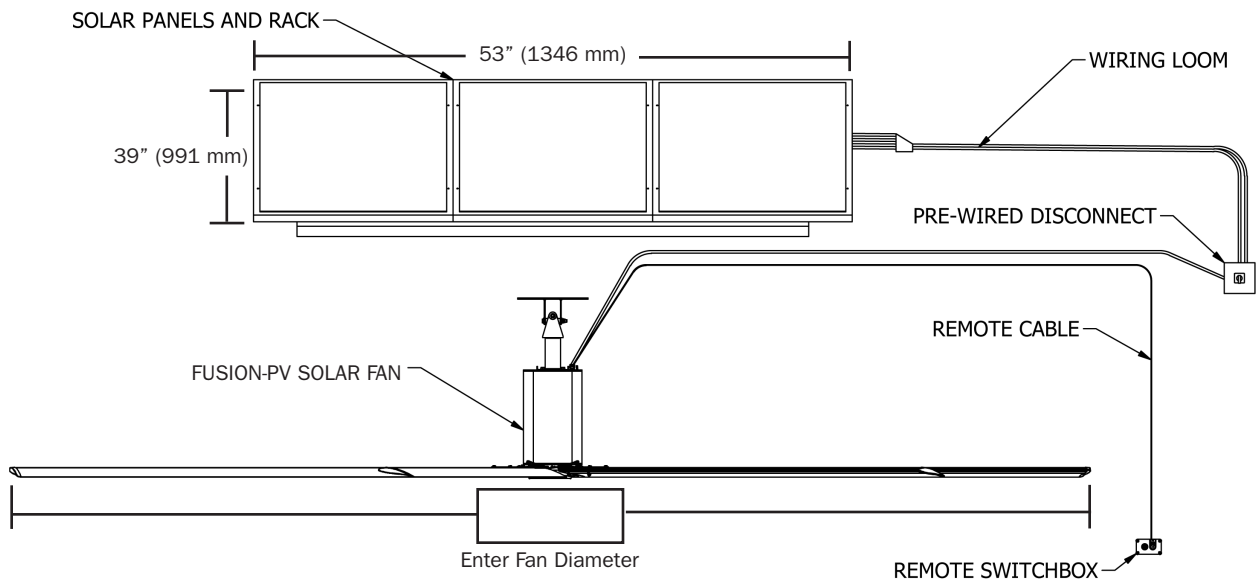

Fan Size	Displacement	Blade Style	Hanging Weight
16 FT	115,332 CFM (3,266 CMM)	Wickerbill	150 lbs. (68 kg)
18 FT	134,451 CFM (3,807 CMM)	WhisperFoil XL	185 lbs. (84 kg)
20 FT	151,030 CFM (4,277 CMM)	WhisperFoil	185 lbs. (84 kg)