

# Air-Powered Dock Levelers

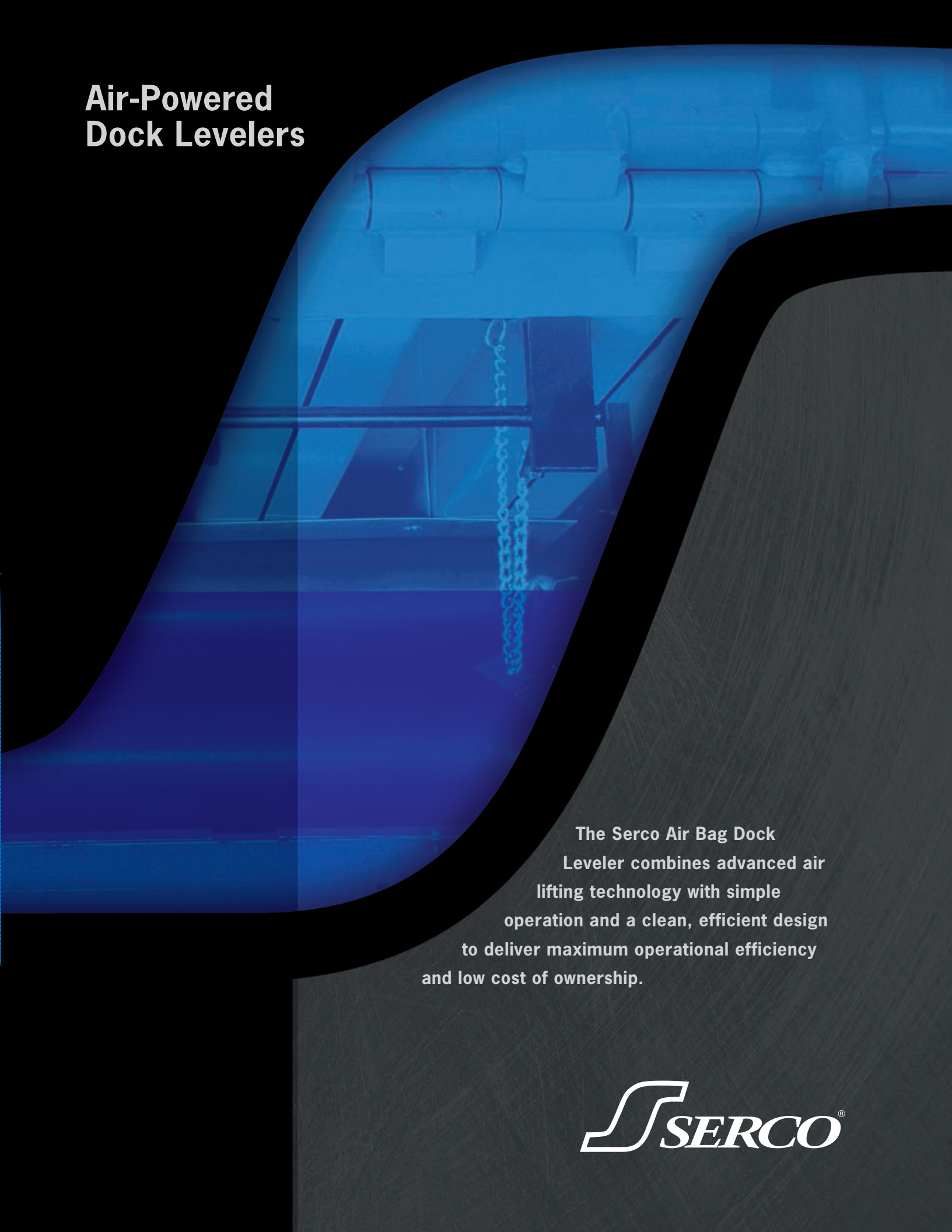

The Serco Air Bag Dock Leveler combines advanced air lifting technology with simple operation and a clean, efficient design to deliver maximum operational efficiency and low cost of ownership.

 **SERCO**<sup>®</sup>

# THE SERCO AIR BAG DOCK LEVELER:

**Push-Button Convenience, Proven Performance.  
Efficient Operation. All At An Affordable Price.**

## **LOW-PRESSURE AIR BAG TECHNOLOGY FOR TOUGH, RELIABLE PERFORMANCE.**

The Serco Air Bag Dock Leveler utilizes the same concepts and the same laws of physics that have made low-pressure air bags a tough, proven lifting technology for over 50 years.



▲ The air bag is easily removed

## **NO SPRINGS. NO HOLD-DOWN. NO WORRIES.**

The Air Bag Dock Leveler is activated by a simple push-button located on the interior loading dock wall. Push and hold and the two-stage, single speed fan inflates the air bag to raise the deck. Releasing the button allows the deck to descend to the trailer, reversing the air direction back through the self-cleaning fan motor.



▲ Structural beams are fully welded to the front header assembly and are designed to conform to out-of-level trucks. Patented split-box beam model shown.

## **HEAVY-DUTY SERCO STRENGTH. STANDARD ON ALL MODELS.**

The leveler deck and lip are manufactured with a heavy-duty, high-tensile steel (depending on selected capacity), with a unique beam design that can withstand repeated impacts of fully-loaded forklifts. The torsionally-capable beam design provides the strength required for fully-loaded forklifts and enables the deck to conform to out-of-level trailers.



▲ The rugged Hydra-Cam-Plus lip extension allows the lip to extend smoothly at the top of the cycle.

## **THE CLEAN FRAME®: EASY ACCESS BY DESIGN.**

Serco's unique CLEAN FRAME® design provides full structural integrity without conventional front frame members. The CLEAN FRAME® design allows wide-open access to the leveler pit for easy clean-up of spills, trash removal and routine maintenance.

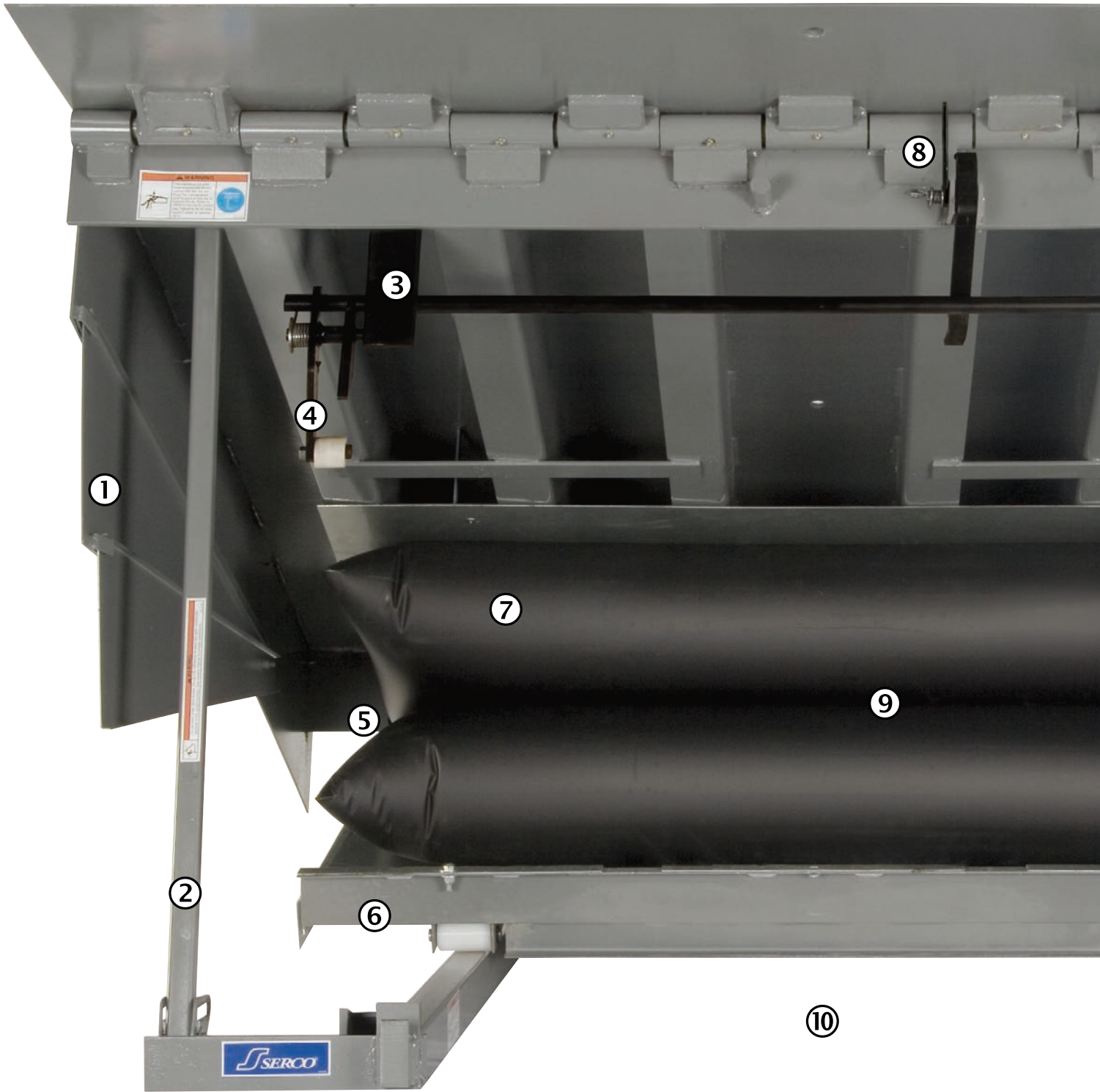

◀ There's no need for special electrical services. Our 10-amp fan with two-stage, single-speed, self-cleaning, filtered UL-approved fan motor uses the same 110-volt power that operates your dock lights.



◀ Simple, easy push button control. Push to raise the door, push to lower, it could be that easy.



- ① Full-range telescopic toe guards.
- ② Integral maintenance strut for deck support.
- ③ Structural Safety legs provide support at and below-dock loading.
- ④ Optional Reflex™ Anti-Stump-Out System with patented sensor roller rides along a reinforced cam surface, providing fluid free-float motion while also providing a measure of free-fall protection in the event of premature trailer separation.
- ⑤ Exclusive SafeTFrame™ provides superior structural support and level interface with warehouse floor.
- ⑥ Pan can be removed for additional easy pit clean-out.
- ⑦ Polyvinylchloride-coated polyester fiber air bag lifting mechanism.
- ⑧ Integral lip support latch.
- ⑨ High volume, low-pressure air bag lifting mechanism.
- ⑩ CLEAN FRAME® pit design for easy clean-up, maintenance and inspection.
- ⑪ Nite-locks prevent unauthorized entry.
- ⑫ Optional 18" or 20" lip for longer lip purchase.
- ⑬ Lip extension automatically extends lip at full height.

AIR-POWERED DOCK LEVELERS

## 5-YEAR GUARANTEE

Serco guarantees the Air Bag Dock Leveler will stand up to the toughest conditions. To prove it, we offer a **5-Year Unlimited Parts & Labor Guarantee on the air bag, seals, fittings, gaskets, hoses and motor.**

Push-button operation.  
Deck and release  
can't be easier than that.



## A SAFER, STRONGER DOCK LEVELER

**FOR DECADES** all dock levelers installed in a concrete pit have required an installer to place and weld steel shim under the rear frame in order to level the device and provide long-term support. This conventional process can lead to install errors as installers are often working under the dock leveler in a cramped environment and may not use the correct size shim and/or weld the shim properly. The result... the dock leveler can suffer structural fatigue which may lead to expensive repair or replacement.

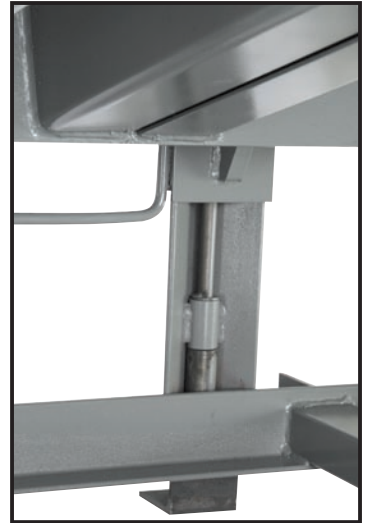
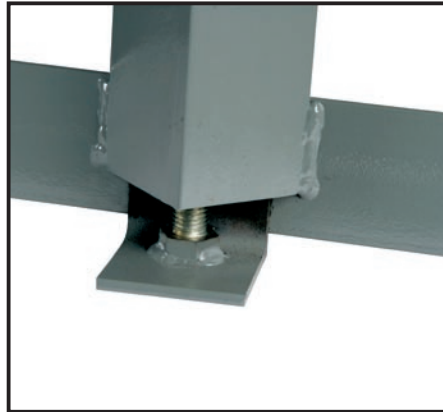
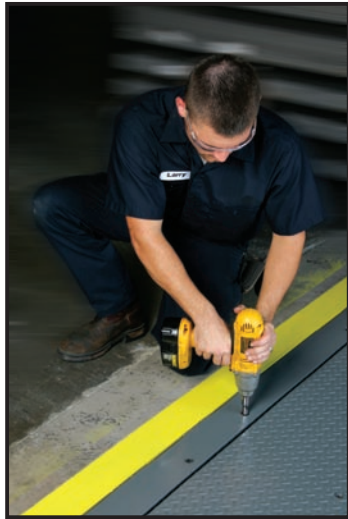

### SAFETFRAME ADVANTAGES:

- Greater structural strength & durability
- Eliminates installation issues common with conventional dock levelers
- Ensures level transition from warehouse floor to dock leveler
- Eliminates premature structural fatigue due to improperly shimmed/installed dock leveler

### SERCO AB DOCK LEVELERS SAVE MONEY:

#### MECHANICAL DOCK LEVELER COSTS

**Estimated 5-Year Maintenance Cost:.....\$900.00**

- ▶ Lubrication of over 20 points every 90 days. Adjust activation springs and lip extension as necessary.
- ▶ Time Required: 45-60 minutes per unit every 90 days  
(Based on 3 hours per year @ \$60/hr.)

**Estimated 5 Year Replacement Parts Cost: .....\$953.00**  
(includes 1.5 hours labor per service call (4 total) @ \$60/hr.)

**Total 5-Year Cost of Ownership: ..... \$1,853.00**  
(Costs shown based on average historical product repair and service data by region)

#### SERCO AIR BAG DOCK LEVELER COSTS

**Estimated 5-Year Maintenance Cost:.....\$200.00**

- ▶ Light oil on four areas every 90 days. No adjustments necessary.
- ▶ Time Required: 10 min. per unit every 90 days  
(Based on 40 minutes per year @ \$60/hr.)

**Estimated 5 Year Replacement Parts Cost: .....\$0.00**  
(includes 1.5 hours labor per service call (4 total) @ \$60/hr.)

**Total 5-Year Cost of Ownership: ..... \$200.00**  
(Costs shown based on average historical product repair and service data by region)

## DURABILITY: IT'S IN THE BAG.

### THE HEART OF THE SERCO AIR BAG DOCK LEVELER

— the air bag — is made of rugged, reinforced coated polyester fibers. The bags are resistant to many chemicals, gasoline, oil spills, cuts, scrapes and even punctures. To ensure operational efficiency even in the toughest conditions (like yours), we put Serco Air Bag lifting technology through extensive testing ...

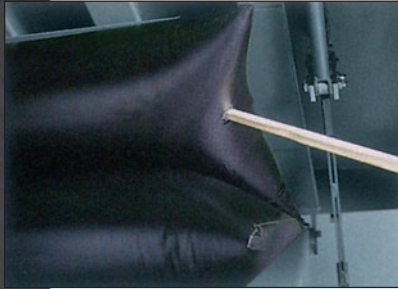

#### PUNCTURE TEST

Even with numerous puncture holes, the Serco Air Bag continued to operate. The holes did not "Star," tear or rip and were easily repaired with an inexpensive vinyl patch,

returning the leveler to full operating efficiency.

#### CYCLE TESTING

Since their introduction in 1994, air powered dock levelers have completed an estimated 47 million cycles with an impressive record of only 0.4% fan/motor claims and 0.1% air bag claims. That's 5.9 million days of operation. In fact, the Serco Air Bag has been tested the equivalent of 20 years of service at a standard dock position (that's over 200,000 cycles) and still worked without permanent damage that impeded the operation of the leveler. Compare air-powered levelers with mechanicals for operational efficiency and cost of ownership and you'll see why they are fast becoming a more popular addition to docks around the world.

**5-YEAR GUARANTEE** the result of these extensive tests is your assurance that the Serco Air Bag Dock Leveler will stand up to the toughest conditions. To prove it, we offer a **5-Year Unlimited Parts & Labor Guarantee on the air bag, seals, fittings, gaskets, hoses and motor.**



▲ Serco Air Bag Dock Levelers feature a low-pressure air bag, manufactured from rugged polyvinylchloride-coated polyester fibers, which operates efficiently from -65° to +200°F (-54° to +93°C).

#### ENVIRONMENTAL TEST

To prove the Serco Air Bag's durability, 100 units were installed in a variety of extreme environments for a full year. Extreme heat, extreme cold, caustic chemicals, high altitude and high traffic volume environments didn't affect the air bag performance in any way.

### INTERLOCK SERCO PRODUCTS FOR THE ULTIMATE IN PERFORMANCE AND SAFETY.



▲ The Serco Air Bag Dock Leveler can be interlocked with other dock devices through the Serco Master Control Panel™ and programmed to act sequentially for maximum dock efficiency and safety.

1612 Hutton Drive, Suite 140  
Carrollton, TX 75006

Tel: 1.800.933.4834  
Fax: 972.389.4769

Email: [sales@sercocompany.com](mailto:sales@sercocompany.com)  
[www.sercocompany.com](http://www.sercocompany.com)



A continuing research program is in effect at Serco. We reserve the right to incorporate product improvement at any time without prior notice.